

A ↑

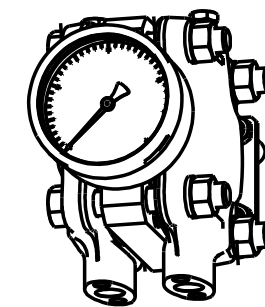
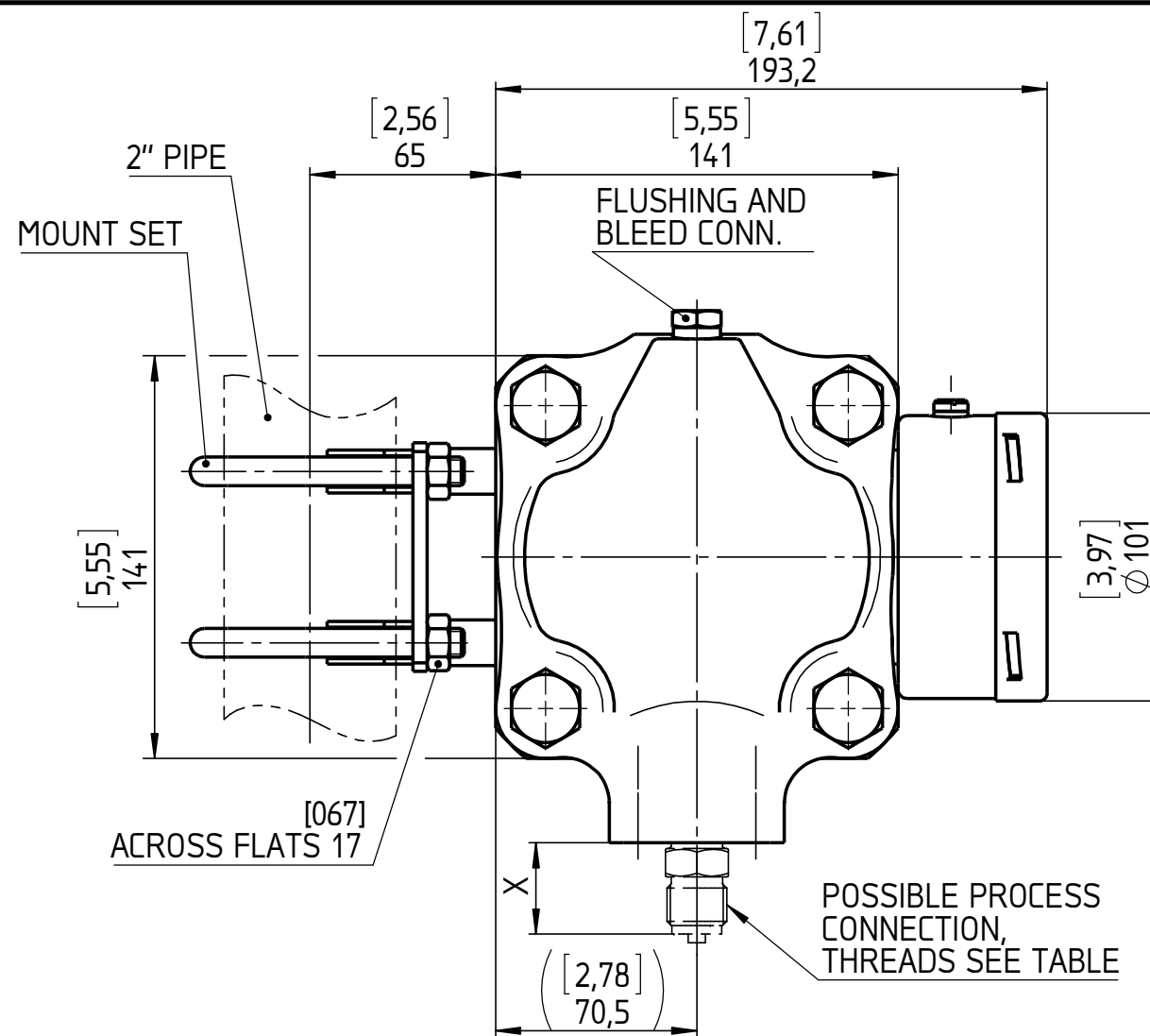
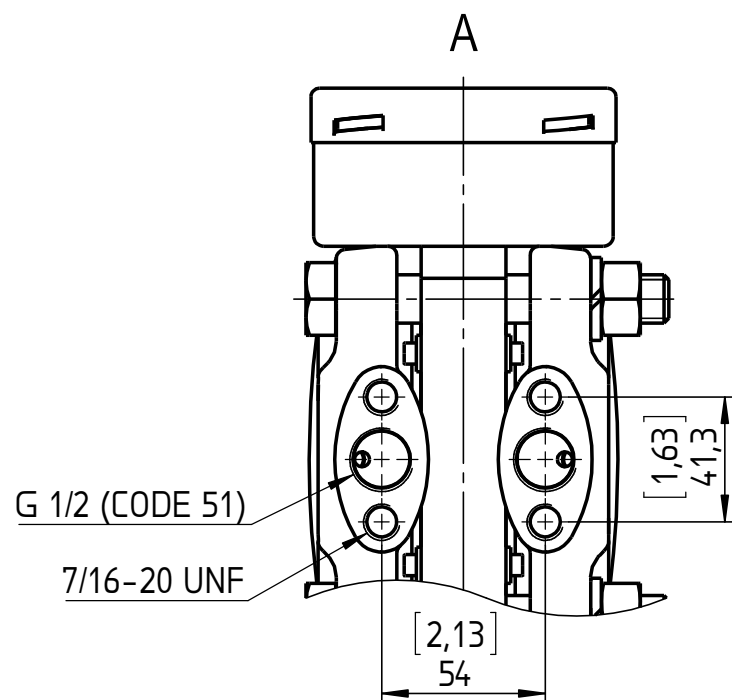

THREADS	CODE	X	
		MATERIAL S	MATERIAL HH
1/4-18 NPT MALE; DIN EN 837	02	33 [1,30]	33 [1,30]
1/2-14 NPT MALE; DIN EN 837	04	36 [1,42]	36 [1,42]
G 1/4 B MALE; DIN EN 837	13	25 [0,98]	25 [0,98]
G 1/2 B MALE; DIN EN 837	15	32 [1,26]	32 [1,26]
M20x1,5 MALE; DIN 3852 TEIL 1	16	32 [1,26]	32 [1,26]
1/4-18 NPT FEMALE	25	25 [0,98]	25 [0,98]
G 1/4 FEMALE; DIN EN 837	27	15 [0,59]	15 [0,59]
1/2-14 NPT FEMALE	50	0	25 [0,98]

This drawing includes confidential information which is the property of ASHCROFT INC. This copy is loaned for a specific purpose, with the understanding that it will not be reproduced or used for any other purpose or disclosed to others, and it will be returned on demand.

Rev.	Description	Date	Na.
		13.06.14	J. Krott
		13.06.14	Th. Wel



Dimensions in mm [inch]

General Dimension
 F5503, NG100, Lower
 40 ÷ 400 mbar, PN100, TM
 DWG. NO. B 076 I 1-F5503-NG100-L-40-400 MBAR-PN100-TM

All specifications are subject to change without notice.