

Installation and Maintenance Instruction Manual



Bourdon Tube Pressure Gauge Model T5500 and T6500

for explosion risk areas pursuant to Directive 2014/34/EU (ATEX)

In the versions:

- ###T5500/T6500###ATEX Bourdon tube pressure gauges without switching contact



Table of Contents:

1	General remarks	3
1.1	Purpose of this manual	3
1.2	Symbols	3
1.3	Limitation of liability.....	3
1.4	Copyright.....	3
1.5	Warranty	3
1.6	Manufacturer address, customer service	3
2	Safety.....	4
2.1	General sources of danger	4
2.2	Intended use	4
2.3	Operator's responsibility	4
2.4	Personnel qualification.....	4
2.5	Signs/safety marking	5
2.6	Safety devices.....	5
2.7	Environmental protection	5
3	Use in potentially explosive atmospheres according to Directive 2014/34/EU ATEX.....	5
3.1	Range of use:.....	5
3.2	Special operating conditions for safe use in potentially explosive atmospheres.....	8
4	Technical data	8
5	Marking of the device	8
6	Structure and function	8
6.1	Overview	8
6.2	Functional description	9
6.3	Description of the components	9
6.4	Accessories.....	9
7	Transportation	9
7.1	Delivery	9
7.2	Storage	10
8	Assembly/Installation.....	10
8.1	Preparation	10
8.2	Requirements for the installation site.....	10
8.3	Process connection.....	10
8.4	Starting up.....	12
8.5	Subsequent relocation of the gauge	12
9	Maintenance	12
9.1	Function check and recalibration	12
9.2	Cleaning and maintenance	12
10	Faults	13
10.1	Behavior after rectifying the fault	13
11	Dismantling & disposal	13
11.1	Disassembly.....	13
11.2	Disposal	14
12	Appendix	14
12.1	Data Sheet Bourdon Tube Pressure Gauge T5500/T6500	14
12.2	Declaration of conformity for Bourdon tube pressure gauges without contact function	15

1 General remarks

The pressure gauge described in these operating instructions is designed using the latest standards, guidelines and findings. During the manufacturing processes, all components are subject to our high quality and environmental criteria. For this purpose, we maintain certified management systems according to ISO 9001 and ISO 14001. For the special requirements of devices for intended use in potentially explosive atmospheres, we maintain a management system according to ISO 80079-34.

1.1 Purpose of this manual

These operating instructions contain basic instructions that must be followed for the installation, operation and maintenance of the device. It must be read by the installer, the operator and the specialist personnel responsible for the device before the device is installed and commissioned. These operating instructions must always be available at the place of use.

The following sections on general safety instructions 0as well as the following special instructions on intended use 2.2to disposal 11.2 contain important safety instructions, the non-observance of which may cause health and safety hazards to people, in particular to workers, and possibly to domestic and farm animals, as well as property.

1.2 Symbols

Warning.



...indicates a potentially hazardous situation, the non-observance of which may cause hazards to the health and safety of people, especially workers, and possibly to domestic and farm animals, as well as property.



Information.

... highlights important information for efficient and trouble-free operation.

1.3 Limitation of liability

Improper use of the equipment, failure to observe the operating instructions, use of unqualified personnel for installation and maintenance work, or unauthorized modifications to this equipment will inevitably result in the loss of liability claims against the equipment manufacturer.

1.4 Copyright

These operating instructions may only be reproduced and passed on as a complete document without the special consent of the publisher.

Subject to technical changes.

1.5 Warranty

For the product described here we grant warranty according to § 6 warranty for defects, in our General Terms and conditions of delivery and payment.

1.6 Manufacturer address, customer service

Ashcroft Instruments GmbH

Max Planck Street 1

D-52499 Baesweiler

Tel.: +49 (0) 2401/808-888

Fax.: +49 (0) 2401/808-999

Mail: customer.service@ashcroft.com

Web: www.ashcroft.eu

2 Safety

2.1 General sources of danger

Pressure gauges are pressurized parts whose failure can lead to dangerous situations. The selection of the pressure gauge should be made according to the rules of EN 837-2.

2.2 Intended use

The devices may only be used for the purpose intended by the manufacturer.

The intended use of the devices, determined by the manufacturer, is the direct indication of negative and positive overpressures in potentially explosive atmospheres.

According to the Pressure Equipment Directive 2014/68/EU, the device is classified as pressure-maintaining equipment without a safety function in accordance with Article 4(3) of the Directive.

When operating the device, care must be taken to ensure that the medium used is harmless to the selected device material. Process media that exhibit changes in the state of aggregation within a range of application can influence the functionality. Negative influences must be avoided for this reason. The process condition of these media must be within the technical limits of the device.

Further technical data on the intended use are summarized in the product data sheet, see section 12.1 these instructions.

2.3 Operator's responsibility

Instructions for the proper operation of the device must be observed. They are to be provided by the operator, the respective qualified personnel for installation, maintenance and operation. Hazards due to magnetic fields, electrostatic charges and leaking media due to improper connection of the device must be excluded. The device must be included in the equipotential grounding within the system; this can be ensured by selecting electrically conductive seals.

The device must be taken out of operation and secured against unintentional operation if it must be assumed that safe operation is no longer possible (see chapter 10, Faults).



Opening the device and performing technical modifications by the customer violate the explosion protection approval and are not permitted.

The operational safety of the device and the manufacturer's warranty are only guaranteed if the device is used as intended. The device design, as well as a possible housing filling, must be adapted to the medium and potentially explosive atmosphere used in the plant. The limit values specified in the technical data must not be exceeded.

The safety instructions listed in this operating manual, existing national regulations for accident prevention and internal work, operating and safety regulations must be observed by the operator. Furthermore, he is responsible for ensuring that all prescribed maintenance, inspection and assembly work is carried out by authorized and qualified personnel.

The device is to be regarded as a pressure-maintaining part of a plant in a potentially explosive atmosphere. The operator of this plant is obliged to carry out an ignition hazard analysis and a zone classification.

2.4 Personnel qualification

The device may only be installed and commissioned by trained specialist personnel.

Specialized personnel are persons who are able to perform the work assigned to them due to their specialized training, experience and knowledge of the country-specific regulations, applicable standards and guidelines. For explosion-protected devices, the personnel must be trained or instructed or authorized to work on explosion-protected devices in hazardous areas.

2.5 Signs/safety marking

The device is provided with a label. The label shows the type designation, measuring range, serial number, year of manufacture, certificate of approval number, filling medium, Ex marking (including X for special conditions of use) and manufacturer.

On the dial the manufacturer, measuring unit, accuracy class, note Silicone-free, note Oxygen-Service and the applied standard are visible.

The device may have other labels and safety marks indicating special conditions of use:

- Note on calibration
- Note on the use of the manual, Note on the use of the vent plug.

The operator must check the label, which is important for the use in potentially explosive atmospheres, at regular intervals to ensure that it remains legible.

The outer packaging is labeled with the type designation, order number, item number, measuring range and manufacturer's data.

2.6 Safety devices

This unit is equipped with a blow-out rear cover (unit type T6500) or blow-out disc (unit type T5500). For a description, see Chapter 6.3.4. The window is made of laminated safety glass, no other material options are permitted here.

2.7 Environmental protection

This device may optionally contain filling liquid (e.g. glycerin or silicone oil). The provisions of the Regulation on Registration, Evaluation, Authorization and Restriction of Chemicals (REACH) 2006/1907/EC must be observed, the corresponding safety data sheets of the manufacturers of the chemicals, are available for download on our website. At the end of the product life cycle we recommend to recycle the devices, as they are mostly made of stainless steel. Instructions for disassembly, material separation and disposal can be found in chapters 11.1 and 11.2

3 Use in potentially explosive atmospheres according to Directive 2014/34/EU ATEX

3.1 Range of use:

Potentially explosive atmospheres Zone 1 and 2, as well as 21 and 22, hazard due to gases and dry dusts.

The permissible environment has the usual oxygen content (21%), ambient pressure 80 kPa (0.8 bar) to 110 kPa (1.1 bar).

The requirements of the applicable standards EN ISO 80079-36, EN ISO 80079-37, EN 60079-0 were considered by an ignition hazard assessment. The applicable requirements of these standards have been met.

The documentation has been filed with TÜV-Nord-Cert NB 0044 (see Declaration of Conformity).

Ambient temperatures:

Execution	Min. / Max. permissible ambient temperature
Dry finish	-40°C to +60°C
PLUS! TM Performance	-40°C to +60°C
Glycerine filled devices	-7°C to +60°C
Silicone filled devices	-40°C to +60°C
Halocarbon filled devices	-40°C to +60°C

The temperature influence on the accuracy in the case of a deviation from the reference temperature 20°C according to DIN EN 837-1 (chap. 9.1) is max. $\pm 0.4\%$ / 10 K of the full scale value.

To avoid additional influences on the device, they must not be exposed to direct sunlight during operation.

Fluid Temperatures:

Permissible max. medium temperature in the measuring system	
Dry finish	Liquid filled devices
≤150°C	≤100°C

The medium temperature depends on the ignition temperature of the surrounding gas, vapors or dust, on the design of the device, especially the pressure change rate and the surface, as well as the ambient temperature and other external heat sources. The device itself does not have its own heat source.



With gaseous substances, the temperature can increase due to heat of compression. Rapid pressure changes should always be avoided. As a suitable protective measure, it is recommended to reduce the rate of pressure change.

Maximum rate of pressure change: 4 / min

The devices are calibrated up to a measuring range of 70 bar with the medium gas, above that liquids are used.

Temperatures in explosive atmospheres - Gases and vapors

EPL	Temperature classes Ignition temperatures <u>for gases and vapors</u>	Permissible, max. surfaces incl. ambient temperature	
		Dry finish	Liquid filled devices
Gb	T1 (> 450°C)	150°C	100°C
	T2 (> 300°C ... ≤ 450°C)	150°C	100°C
	T3 (> 200°C ... ≤ 300°C)	150°C	100°C
	T4 (> 135°C ... ≤ 200°C)	130°C	100°C
	T5 (> 100°C ... ≤ 135°C)	95°C	95°C
	T6 (> 85°C ... ≤ 100°C)	80°C	80°C

The maximum surface temperature including the ambient temperature, for the application on site, depends on the device type with its technical specifications. The lowest temperature limits apply in each case.

Temperatures in explosive atmospheres - Dusts

For the determination of the ignition temperature, the method according to ISO/IEC 80079-20-2 is to be used. This can only be carried out by the user on site for the individual case. The device-specific properties as well as the limit temperatures of the dusts and their form as a deposited layer or in the form of a surrounding dust cloud must be taken into account here. For this reason, the ignition temperatures must be determined separately. In the case of dust layers, the thickness of the dust layer must be taken into account as a further criterion.

EPL	Ignition temperature	Permissible max. surface temperature dusts
Db	Minimum ignition temperature for dust clouds T_{cloud} [°C]	$T_{max} = 2/3 T_{cloud}$
	Minimum ignition temperature with dust layers T_{5mm} [°C].	$T_{max} = T_{5mm} - 75 K$

The device protection for an explosive dust atmosphere, can only be used with the ventilation valve closed.

In case of a malfunction, the maximum medium temperature may be considered as the surface temperature to be determined.

For mounting locations that allow weather influences, these influences must be minimized by suitable measures. To avoid additional heating, the devices must not be exposed to any external heat source during operation! Convection heat from the direct environment of the devices must also be avoided.



The devices must not be operated in potentially explosive areas of a plant in which an explosive mixture of gases and dusts is present in the atmosphere.

Labeling:

Ex marking according 2014/34/EU				Ex marking according ISO 80079-36 / 80079-37				
CE	Ex	II	2G 2D	Ex h	IIC IIIC	T6...T1 T85°C...T450°C	Gb Db	X
CE	Conformity mark CE							
Ex	Explosion protection mark							
II	Group II equipment is intended for use in locations with explosive gas atmospheres, excluding mine gas and/or dust from hazardous mining operations.							
2G	Equipment group for gases and vapors in which an explosive atmosphere may occasionally occur during normal operation.							
2D	Equipment group for dusts in which an explosive atmosphere may occur during normal operation or for a short period.							
Ex h	Marking according to the equipment protection level for non-electrical equipment in potentially explosive atmospheres							
IIC	Suitable for gas atmosphere IIC							
IIIC	Suitable for combustible suspended solids, non-conductive and conductive dust							
T6...T1 T85°C...T450°C	Maximum surface temperatures which are mainly dependent on the operating conditions							
Gb	Equipment protection level for gases containing all potential ignition sources that are effective, which may occur during normal operation, rare and expected malfunctions.							
Db	Equipment protection level for dusts containing all potential ignition sources that are effective, which may occur during normal operation, rare and expected malfunctions.							
X	Special operating conditions must be observed and can be found in the operating instructions.							

3.2 Special operating conditions for safe use in potentially explosive atmospheres

- Maintenance work to be carried out, from chap. 9 (such as refilling the equipment with the filling medium) by unauthorized personnel may result in damage and lead to loss of approval.
- To avoid possible spark generation due to static charge, the device should always be cleaned with a damp cloth.
- The legibility of the nameplates must be checked at regular intervals. It must remain legible throughout the entire period of use of the device. If a reliable reading is no longer given, please contact the manufacturer.
- Impacts on the device must be avoided at all costs. Impacts or shocks can produce sparks.
- It is the responsibility of the operator to evaluate attached process components or accessories together with the delivered device by means of an ignition hazard analysis. The operator must recognize the ignition hazards and prevent them by using appropriate protective measures.
- The operator must comply with the points from chapter 2.3 "Responsibility of the operator".

4 Technical data

For detailed technical data, please refer to the documents in the appendix chapter 12

5 Marking of the device

The nameplate with serial number (format: YYMMxxxxxx) and type designation is located on the housing. The materials used for the wetted parts as well as other device-specific versions are represented by a type coding on the nameplate and can be broken down at any time with the aid of the data sheet. The marking for the hazardous areas, in the form of the description of the type of protection, the permissible ambient temperature and the deposit number, are located in the lower area of the nameplate.



Ashcroft Instruments GmbH
52499 Baesweiler, Germany

160=T6500=S=L=04=L=100BR=X=ATEX=YW=GR=SM=M
P=SG=NH=C3=C4=EN

P_{max}: 1.3 x FS Fill Fluid: Glycerin
T_{amb}: -7 ... 60°C S/N : 201200515594
File No. : 35286061

CE Ex II 2G Ex h IIC T6...T1 Gb X
II 2D Ex h IIIC T85°C...T450°C Db X



6 Structure and function

6.1 Overview

- 1 Bourdon tube
- 2 Socket and process connection
- 3 Movement
- 4 Pointer
- 5 Dial
- 6 Window
- 7 Bayonet ring
- 8 Seal
- 9 Vent valve (available depending on measuring range)
- 10 Case
- 11 Blowout disc/compensating diaphragm

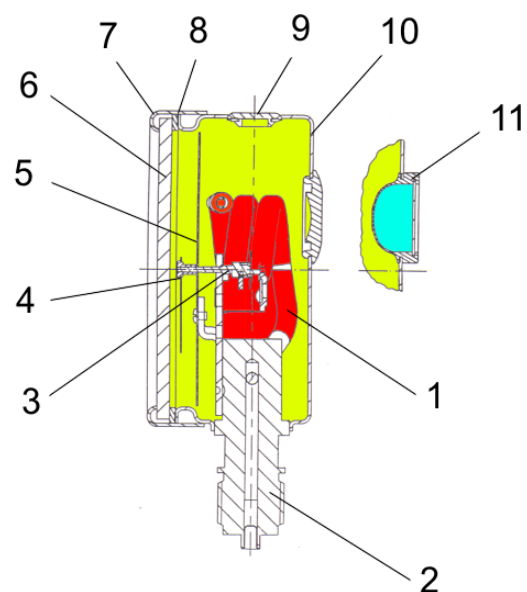

6.2 Functional description

An elastic measuring element in the form of a Bourdon tube (circular or helical, depending on the measuring range) is welded to a socket. It is pressurized on one side from the inside. A pressure transmission medium can be gaseous or liquid, depending on the material and design used.

Pressure loading causes elastic deflection from the normal position. This deflection is proportional to the applied pressure. At the end of the Bourdon tube, a tension rod picks up the deflection and transmits it to a movement. The measured value is displayed on a 270° scale.

The requirements for indicating pressure gauges with Bourdon tubes are in accordance with EN 837-1.

6.3 Description of the components

6.3.1 Dial with pointer

The gauges are equipped with a dial and a pointer according to EN 837-1 for nominal sizes NG 100 mm or NG 160 mm.

6.3.2 Instrument connection

The instrument connection is located on the bottom (Model T5500, T6500) or eccentrically on the back (available on Model T5500 only) of the instrument.

6.3.3 Vent valve

The vent valve (if present) is located on the top of the instrument. When the nipple (pull) is pulled out, the housing is vented and the pressure built up in the housing due to temperature influence is relieved.

When the valve is closed, the degree of protection is IP66/IP67 according to EN 60529 / IEC 60529.

When the valve is open, the degree of protection is reduced to the minimum requirement according to EN 80079-37 chap. 5.2.2a

6.3.4 Blow out back cover/disc

The device has a blow-out disc (model T5500) or a blow-out back cover (model T6500) on the rear wall of the housing. These serve as a safety device in accordance with EN 837-1 and enable automatic compensation of the internal housing pressure, which can be caused by temperature influences in the housing, via a rubber diaphragm.

6.4 Accessories

Please contact the manufacturer for information on special sealing materials and accessories.

7 Transportation

The device must be protected against impact. Transport must be carried out exclusively in the glass-break-proof packaging provided for transport. The device shall only be transported in a cleaned condition (free of residual media).

7.1 Delivery

The delivery is to be checked for completeness and transport damage. In case of transport damage, the delivery is not to be accepted or only with reservation, the extent of damage is to be noted and, if necessary, a complaint is to be initiated. In these cases, please contact our service department.

7.2 Storage

The storage of the devices should exclude external influences as far as possible to avoid damage to the devices. Vibrations or impact effects must be avoided, and the limit values of the storage temperatures must be taken into account.

Permissible storage temperature:

-40 to +60°C

Glycerin filled devices -20°C to +60°C

8 Assembly/Installation

8.1 Preparation

To ensure safe working during installation and maintenance, suitable shut-off valves must be installed in the system, by means of which the unit can be

- depressurized within the relevant plant for the purpose of repair or inspection,
- subjected to a functional check on site.

During assembly/installation work, the system must be secured against being switched on again.

It is recommended to perform the assembly / installation without an existing explosive atmosphere (e.g. ventilated room).

8.2 Requirements for the installation site

- Check the suitability of the device for the process media to be measured,
- Design of the measuring range to the requirements of the measurement,
- A gauge support must be installed if the measuring line does not have sufficient load-bearing capacity,
- Units with blow out device require a minimum distance to the rear of min. 20 mm,
- The installation location must be chosen in such a way that workplaces of the operating personnel are not located at the rear of the measuring device,
- Protection against pressure surges by means of suitable pressure snubbers,
- Protection against mechanical vibration, e.g. by means of a flexible capillary line.
The following limits must not be exceeded under any circumstances:
Frequency of mechanical vibration: max. 150 Hz
Acceleration: max. 0.5 g (approx. 5 m/s²)

8.3 Process connection

The process connections comply with the general technical regulations for pressure gauges. Thread types and materials of the process connections may vary depending on the application.

- Assembly of the device only by authorized and qualified personnel.
- The device must be integrated into the equipotential bonding of the process installation (e.g. by using an electrically conductive seal).
- The pressure pipe must be laid inclined in such a way that, for example, for measurements of fluids no air bubbles can form, and for measurements of gases no water pockets. If the necessary incline is not achieved, then at suitable points water separators or air separators must be installed.
- The pressure measuring line should be kept as short as possible and laid without sharp bends.
- In the case of liquid measuring media, the pressure line must be vented, as trapped air bubbles could lead to a measuring error.
- It must be ensured that the blow-out back cover is not blocked and that a sufficiently large distance to the nearest stationary object is guaranteed.
- If water is used as the measurement medium, the device must be frost-protected.

- The unit is adjusted at the factory for vertical mounting position.



Only use the appropriate open-end wrench to tighten the sealant on the intended wrench flat. The tightening torque depends on the sealant used.

8.4 Starting up

A prerequisite for starting up is the proper installation of all measuring lines. All connection must be laid in such a way that no mechanical forces can act on the device.

Before starting up, the tightness of the pressure connection must be checked.

Any shut-off valves must be opened slowly to avoid pressure surges.

8.5 Subsequent relocation of the gauge



Do not disassemble the device from the measuring point in order to mount it at another measuring point without cleaning it first (cleaning the Bourdon tube). There is a risk of mixing media with unpredictable chemical reactions.

9 Maintenance

The devices are low maintenance. To ensure reliable operation and a long service life of the device, we nevertheless recommend that the device is checked regularly. When carrying out maintenance work on the device, the lines must be depressurized, unintended starting up must be prevented.

9.1 Function check and recalibration

Calibration

For our devices we recommend a calibration interval of:

- Accuracy class ≤ 0.6 annual recalibration.
- Accuracy class ≥ 1.0 recalibration at an interval of two years

Functional tests

The exact test cycles must be adapted to the operating and ambient conditions. When various device components interact, the operating instructions of all other devices must also be observed.

- Check on the display.
- Check on function, in conjunction with downstream components
- Check of pressure lines for damage and tightness.
- Check of filling liquids, the level must not fall below 80 to 85 % of the window diameter

9.2 Cleaning and maintenance

Cleaning is carried out with a non-aggressive cleaning agent and a damp soft cloth to avoid electrostatic charging. In the same work process, care can be taken to detect possible damage to the device at an early stage. If any damage is detected, the unit should be handed over to the manufacturer's service department immediately.

10 Faults

All defective or faulty equipment must be taken out of service. Defective or faulty devices should be handed over to the manufacturer's service department immediately. Under no circumstances repair attempts should be made on site. Device safety can no longer be guaranteed.

Contact details see chap. 1.6

Fault	Possible causes	Possible measures
Jerky or random pointer movement	Defective measuring device due to high vibrations of the plant	Check for mounting errors and installation location. Decoupling plant --- device Replace device if necessary
No zero setting of the pointer with pressure less device	Device was overloaded, operation outside device specification	Replacement of the device, Repair usually no longer possible.
Bent or loose pointer	Damage with transport or external rough impact	Repair by the manufacturer
Cracked window	External influences	Repair by the manufacturer
Leakage with filled device	High solar radiation, operation outside the device specification	Repair by the manufacturer
Case damage	Improper handling	Check installation location, Device must be replaced
Signs of leakage of the measuring system (discoloration of the dial or the filling liquid).	Process media not compatible with the material used for the Bourdon tube, installation location with excessive external influences	Improper use, Replace device Shield installation site or relocate installation site. Attach shields to the device

10.1 Behavior after rectifying the fault

See chapter 8 Assembly/Installation

11 Dismantling & disposal

11.1 Disassembly

- During maintenance work on the unit, the lines must be depressurized and the system must be secured against being switched on again.
- Dismantle the measuring device using a suitable tool
- For devices with case filling, close the vent plug before disassembly



Residual media in and on dismantled measuring instruments can endanger people, the environment and equipment. Sufficient precautionary measures must be taken. If necessary, the devices must be cleaned thoroughly (see notes in the safety data sheets).

11.2 Disposal



At the end of the product life cycle, do not dispose of this product with normal household waste. Take this product to a collection point or a specialist disposal company for recycling of the components.

With the help of the product coding and our data sheets (see Appendix 12.1 available on our website) you will receive the necessary information to be able to carry out a material separation yourself. Our devices described in this manual are mostly made of stainless steels which can be recycled. Before disassembling, check if there is a device filled with filling fluid. This fluid must first be drained off and collected in accordance with the safety instructions in the safety data sheet. Then separate the case ring, which carries the window, from the case using a strap wrench. The sealing ring and flat glass can be removed. Next, remove the pointer and dial, which are made of aluminum. Dismantle the venting and pressure equalization device last, everything else is made of stainless steel.

Materials to be recycled:

- Filling fluid (oil see data sheet)
- Stainless steel (case, case ring, Bourdon tube socket, Bourdon tube, movement see data sheet)
- Dial and pointer (aluminum)
- Window (see data sheet glass or plastic)
- Seals (sealing ring of the sight glass, venting device, pressure relief device)

Please help to protect our environment!



Some of the product materials can be reused if you take the product to a collection point or to a waste management company. By reusing some parts or raw materials from used products, you make an important contribution to protecting the environment.

Our products are delivered in optimized packaging. This essentially means that materials are used which can be recycled as secondary raw materials at the local disposal service. For more information on the disposal of packaging, please contact your local administration.







12 Appendix



12.1 Data Sheet Bourdon Tube Pressure Gauge T5500/T6500

Detailed data sheets are available directly from the manufacturer (see 1.6 Manufacturer address, customer service).

Model	Designation	Document
T5500	Stainless Steel Pressure Gauge Model T5500	DS T5500
T6500	Solid Front Stainless Steel Pressure Gauge Model T6500	DS T5500

12.2 Declaration of conformity for Bourdon tube pressure gauges without contact function

 ASHCROFT® Trust the shield™	EU-Konformitätserklärung EU-Declaration of Conformity DIN EN ISO IEC 17050-1:2010	 Management System ISO 15001:2015 www.tuv.com 01 9046100
Ashcroft Instruments GmbH Max-Planck-Straße 1 52499 Baesweiler		
erklärt in alleiniger Verantwortung, dass die mit CE gekennzeichneten Produkte <i>declares in sole responsibility that the products marked with CE</i>		
Gerät: <i>Equipment:</i>	Druckmessgerät vom Typ T5500 / T6500 mit federelastischem Messglied <i>Pressure gauge Type T5500 / T6500 with elastic measure element</i>	
Kennzeichnung: <i>Marking:</i>	  II 2G Ex h IIC T6...T1 Gb X II 2D Ex h IIC T85°C...T450°C Db X Ta = -40°C to +60°C	
Optional: GR <i>Option:</i>	Ta= -7°C bis +60°C mit Glycerin Füllung <i>Ta= -7°C bis +60°C with glycerine filling</i>	
Herstellungsdatum: <i>Date of manufacture:</i>	ab 03.12.2020 <i>from 03.12.2020</i>	
die grundlegenden Sicherheits- und Schutzanforderungen erfüllen, in Übereinstimmung mit den unten genannten Richtlinien und Normen. Die Konformitätsaussage bezieht sich auf die Konzeption und Fertigung der oben genannten Produkte. <i>the fundamental safety and protection requirements passed in accordance with the guideline and standards listed below. This declaration of conformity refers to the design and manufacture of the above products.</i>		
Richtlinie <i>Directive</i>	2014/34/EU „Geräte und Schutzsysteme zur bestimmungsgemäßen Verwendung in explosionsgefährdeten Bereichen“ <i>“equipment and protective systems intended for use in potentially explosive atmospheres”</i>	
Angewendete harmonisierte Normen <i>Used harmonized Standards</i>	DIN EN ISO 80079-36:2016, DIN EN ISO 80079-37:2016, DIN EN 1127-1:2019	
Benannte Stelle <i>Notification Body</i>	Code number of notified Body: 0044 TÜV NORD CERT Langemarkstrasse 20, 45141 Essen, Germany	
Hinterlegungsnummer: <i>Dossier File No.:</i>	35286061	
Richtlinie <i>Directive</i>	⁽¹⁾ 2014/68/EU „Druckgeräterichtlinie“ <i>„Pressure Equipment Directive“</i>	
Angewendete Prüfnormen: <i>Used test standards:</i>	EN 837-1,2,3:1996	
⁽¹⁾ PS >200 bar und V <0,1l, Artikel 4 Drucktragende Ausrüstungsteile, Modul A <i>PS >200 bar and V <0,1l, Article 4 Pressure Accessories, Module A</i>		
Ashcroft Instruments GmbH	Fon: +49 (0)2401-808-888	eMail: customer.service@ashcroft.com www.ashcroft.eu
 		

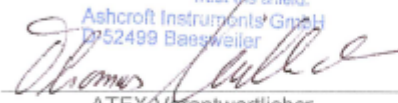
 EU-Konformitätserklärung EU-Declaration of Conformity DIN EN ISO IEC 17050-1:2010		 Management System ISO 9001:2015 www.tuv.com TÜV RHEINLAND
Richtlinie <i>Directive</i>	2011/65/EU „Richtlinie zur Beschränkung der Verwendung bestimmter gefährlicher Stoffe in Elektro- und Elektronikgeräten“ <i>“Directive on the restriction of the use of certain hazardous substances in electrical and electronic equipment”</i> 2015/863/EU „Änderung von Anhang II der Richtlinie 2011/65/EU“ <i>“Amending Annex II to Directive 2011/65/EU”</i>	
Einstufung <i>Classification</i>	Einstufung des Produktes nach Anhang II Punkt 9 der Richtlinie „Überwachungs- und Kontrollinstrumente einschließlich Überwachungs- und Kontrollinstrumente in der Industrie“ <i>Classification of the product according to Annex II, point 9 of the Directive “Monitoring and control instruments, including industrial monitoring and control instruments”.</i>	
Stoffbeschränkungen <i>Substance restrictions</i>	Beschränkungen und Höchstkonzentrationen in homogenen Werkstoffen in Gewichtsprozent: <i>Limitations and maximum concentrations in homogeneous materials in percent by weight:</i> Blei (0,1 %) <i>Lead (0,1 %)</i> Quecksilber (0,1 %) <i>Mercury (0,1 %)</i> Cadmium (0,01 %) <i>Cadmium (0,01 %)</i> Sechswertiges Chrom (0,1 %) <i>Hexavalent chromium (0,1 %)</i> Polybromierte Biphenyle (PBB) (0,1 %) <i>Polybrominated biphenyls (PBB) (0,1 %)</i> Polybromierte Diphenylether (PBDE) (0,1 %) <i>Polybrominated diphenyl ethers (PBDE) (0,1 %)</i> Di(2-ethylhexyl)phthalat (DEHP) (0,1 %) <i>Bis(2-ethylhexyl) phthalate (DEHP) (0,1 %)</i> Butylbenzylphthalat (BBP) (0,1 %) <i>Butyl benzyl phthalate (BBP) (0,1 %)</i> Dibutylphthalat (DBP) (0,1 %) <i>Dibutyl phthalate (DBP) (0,1 %)</i> Diisobutylphthalat (DIBP) (0,1 %) <i>Diisobutyl phthalate (DIBP) (0,1 %)</i>	
Das oben benannte Produkt erfüllt die derzeit gültigen Vorschriften der Richtlinie 2011/65/EU des Europäischen Parlaments und des Rates vom 8. Juni 2011 sowie der Delegierten Richtlinie 2015/863/EU der Kommission vom 31.03.2015. <i>The above-mentioned product comply with the currently valid provisions of Directive 2011/65/EU of the European Parliament and of the Council of 8 June 2011 and the Commission Delegate Directive 2015/863/EU of 31 March 2015.</i>		
Baesweiler, den 06.01.2021 Ort und Datum <i>Place and date</i>	 Ashcroft Instruments GmbH 752499 Baesweiler  ATEX Verantwortlicher ATEX Manager	
Ashcroft Instruments GmbH Fon: +49 (0)2401-808-888 eMail: customer.service@ashcroft.com www.ashcroft.eu 